



HYTORC®

DIVISION UNEX CORPORATION

333 STATE ROUTE 17 NORTH
MAHWAH, N.J. 07430-9895
Tel: (201) 512-9500
Fax: (201) 512-0530

Form No. 107265

Parts List for:

HYTORC-AIR

AIR/HYDRAULIC PUMP GENERAL SECTION

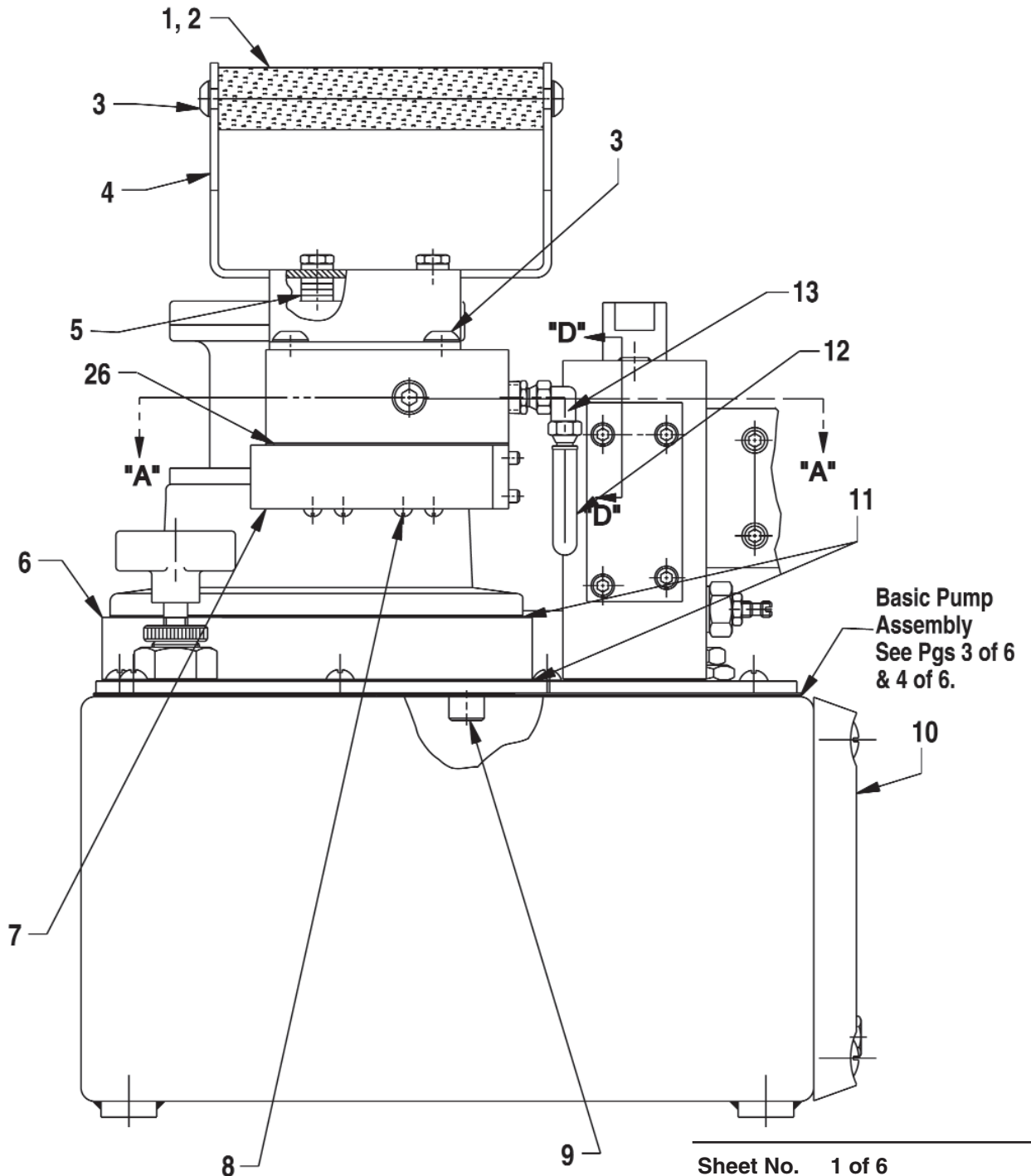

Sheet No. 1 of 6

Rev 14 Date: 09 Nov 2004

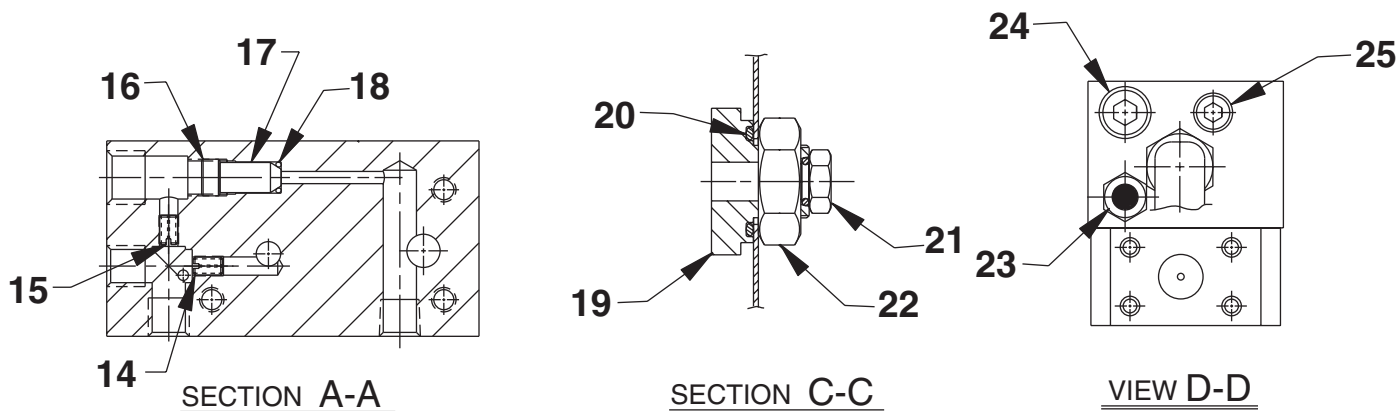

Item No.	Part No.	No. Req'd	Description
1	252154	1	Handle
2	251600	1	Handle Grip
3	251437	5	Hex Soc. Screw
4	58807GY8	1	Handle Bracket
5	12719	2	Plain Washer (For 1/4 Bolt)
6	421259	1	Motor Base
7	351276	1	4-Way Air Pilot Valve
8	252175	4	Slotted Screw (Torque to 50 in. lbs., 4 places)
9	11531	4	Hex Soc. Screw (Torque to 250 in. lbs., 4 places; 3/8-16 UNC X 2" Lg.)
10	350431	1	Temp Gauge
11	*351277	2	Gasket
12	*252226	.75 ft	Nylon Tubing
13	*252176	1	90° Elbow Fitting
14	†214990	1	Restrictor Screw
15	†252173	1	Orifice Screw (Note: Do not apply Loctite to threads.)
16	†17240	1	Hollow Locking Screw (3/8-24 UNF X 3/16 Lg. Apply Loctite #242 or Equiv.. and finger tight)
17	†253531	1	Check Valve (3000 PSI)
18	†10265	1	O-ring (5/16 X 3/16 X 1/16)
19	351000	1	Drain
20	14725	1	O-ring (1-1/8" X 15/16 X 3/32)
21	17147	1	Plug Fitting (1/4 Tube)
22	10396	1	Hex Jam Nut (3/4-16 UNF)
23	251599	1	Filler/Breather Cap
24	10479	1	Plug Fitting (1/4 NPTF)
25	10427	1	Plug Fitting (1/8 NPTF)
26	252580	1	Gasket

Part numbers marked with an asterisk (*) are contained in Repair Kit No. 090210.
 Part numbers marked with a dagger (†) are contained in Repair Kit No. 252391.

Note: Shaded areas reflect last revision(s) made to this form.

FINAL ASSEMBLY (TOP VIEW)

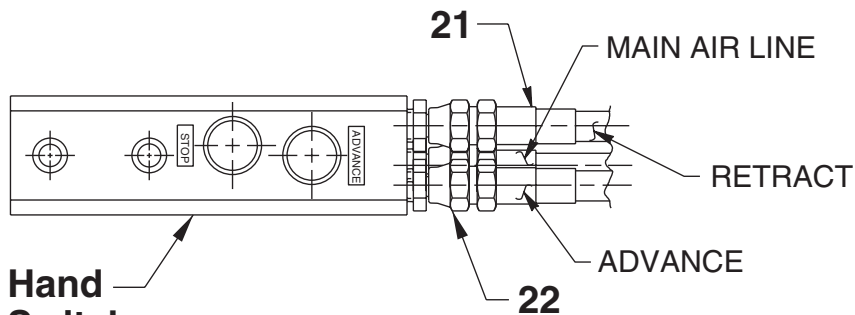
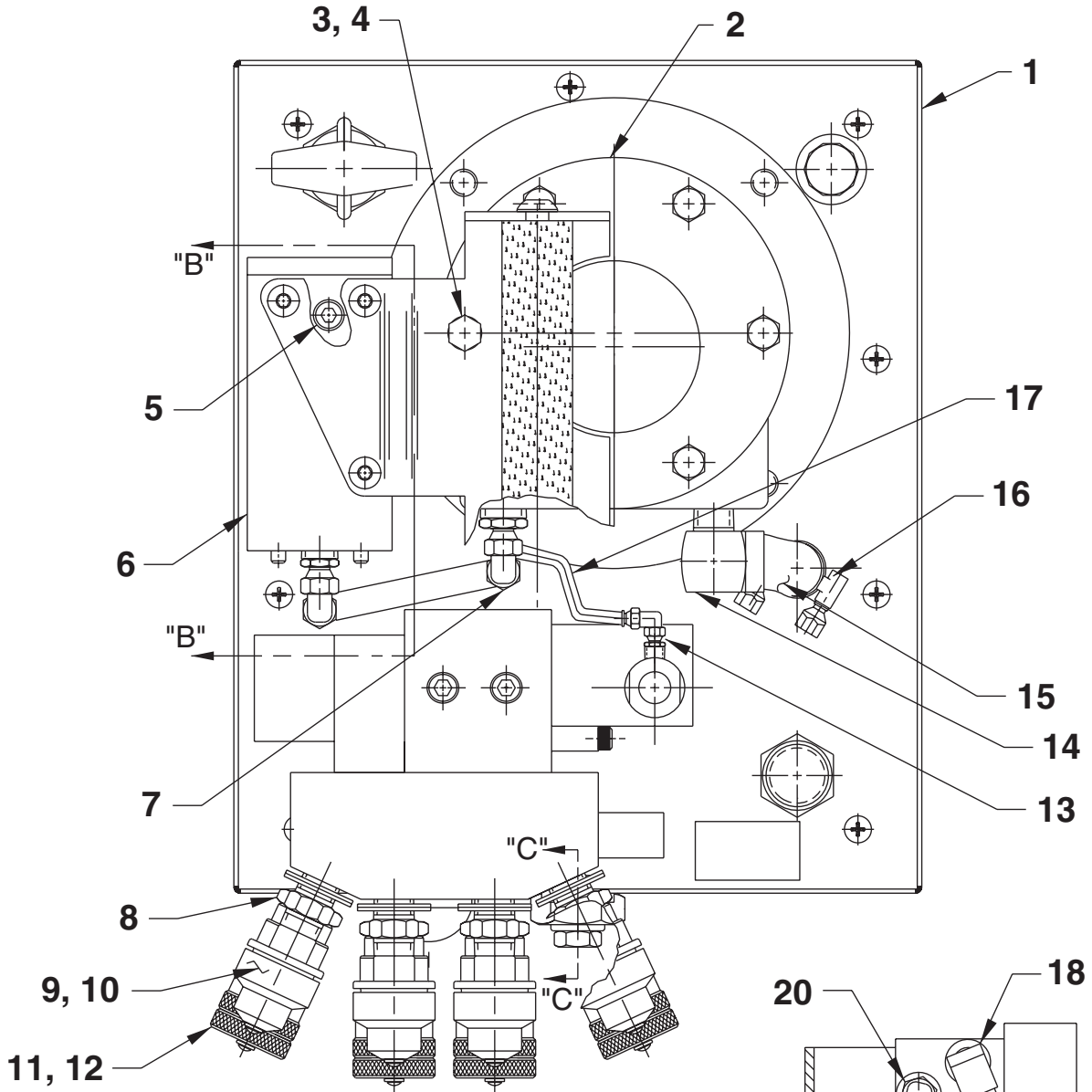

Hand
Switch
Assembly See
back sheet 6 of 6

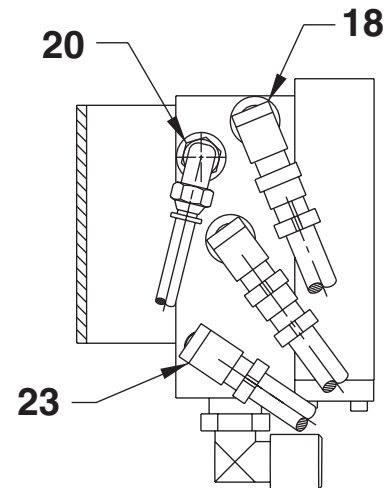

SECTION B-B

Parts List, Form No. 107265, Back sheet 2 of 6

Item No.	Part No.	No. Req'd	Description
1	65599BK2	1	Reservoir
2	421304GY8	1	Air Motor (4 Hp.)
3	10018	2	Cap Screw (1/4-28 UNF X 1-1/4" Lg.)
4	12719	8	Plain Washer (For 1/4 Bolt)
5	15499	1	Plug Fitting (1/8" PTF)
6	†58780	1	Manifold Body
7	*252177	1	90° Elbow Fitting
8	10672	4	Straight Fitting (1/4 NPTF)
9	251798	4	Quick Plug Coupler
10	252069	4	Dust Cap
11	251797	4	Quick Coupler
12	252068	4	Dust Cap
13	*250463	1	90° Elbow Fitting
14	212897	1	90° Elbow Fitting
15	212898	.33 ft	Pressure Hose
16	12367	2	Hose Clamp
17	*15883	.6 ft	Tubing
18	14440	2	90° Elbow Fitting
20	250463	1	90° Elbow Fitting
21	•421610	1	Three Strand 15' Hose
22	•208218	3	Straight Fitting (1/8 NPTF)
23	14680	1	90° Elbow Fitting

Part numbers marked with an asterisk (*) are contained in Repair Kit No. 090210.

Part numbers marked with a dagger (†) are contained in Repair Kit No. 252391.

Part numbers marked with a bullet (•) are contained in Repair Kit No. 090227-2.

BASIC PUMP ASSEMBLY W/ACCESSORIES

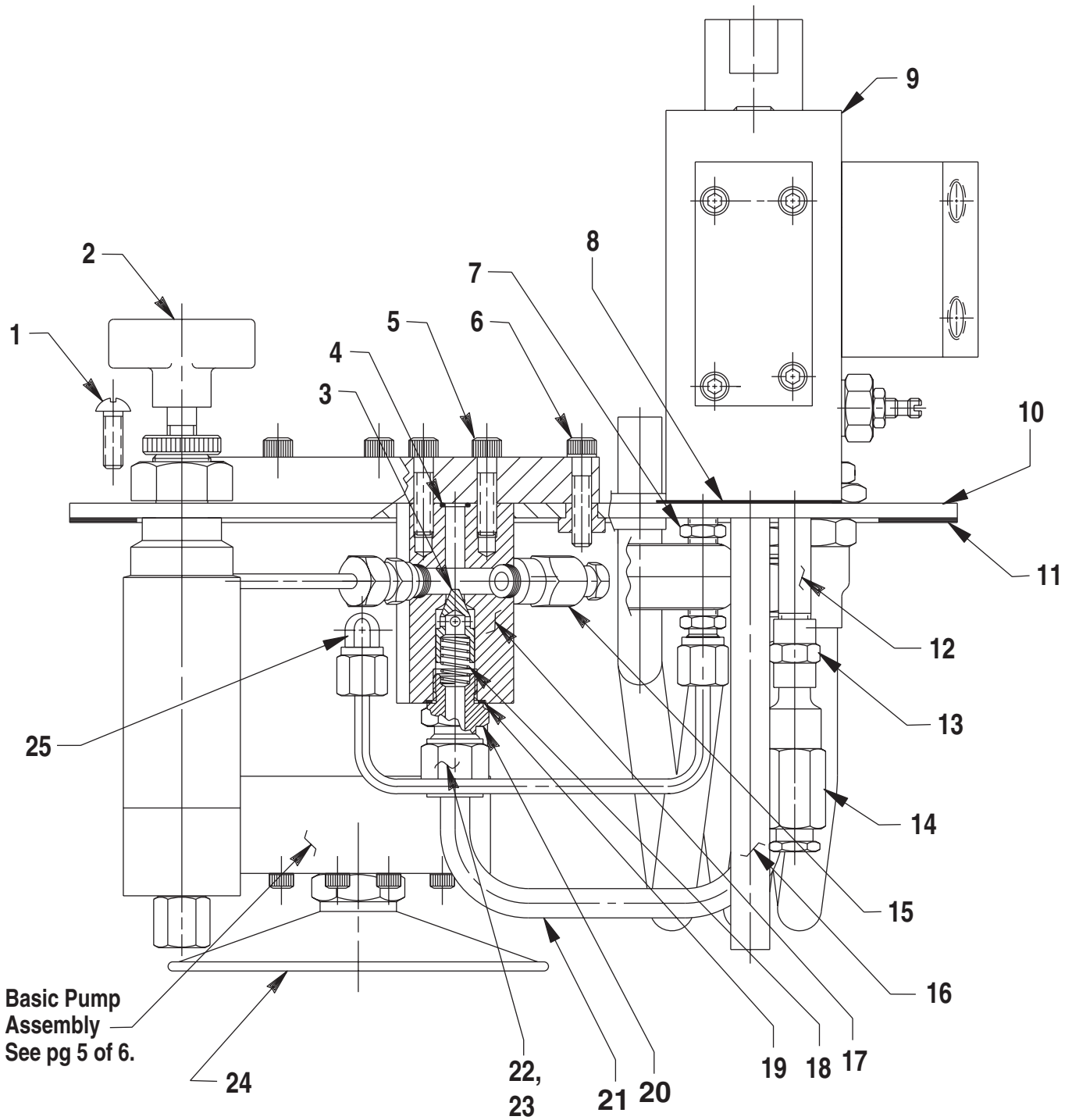

Basic Pump Assembly
See pg 5 of 6.

Parts List, Form No. 107265, Back sheet 3 of 6

Item No.	Part No.	No. Req'd	Description
1	10177	10	Phillips Screw (1/4-20 UNC X 3/4 Lg.)
2	252284	1	Pressure Regulator Assembly (See Form No. 107277)
3	20771	1	Poppet
4	10266	1	O-ring (3/8 X 1/4 X 1/16)
5	10015	2	Hex Soc. Screw (1/4-28 UNF X 1" Lg.; Torque to 130/180 in. lbs.)
6	10016	2	Hex Soc. Screw (1/4-20 UNC X 1" Lg.)
7	11421	1	Straight Fitting
8	351095	1	Gasket
9	421248	1	Valve Assembly (See Form No. 105549)
10	65186GY8	1	Cover Plate
11	*40164	1	Cover Plate Gasket
12	15456	1	Straight Fitting
13	18841	1	Straight Fitting
14	*21278-15	1	Relief Valve (Set at 1,500/1,700 PSI)
15	*21278	1	Relief Valve (Set at 10,100/10,700 PSI)
16	200609	1	Drain Tube
17	20776	1	Valve Body
18	10425	1	Spring (3/8 O.D. X 3/4 Lg.)
19	10261	1	Special Washer (3/4 X 19/32 X 1/32)
20	20770	1	Connector Fitting (Torque to 40/50 ft. lbs.)
21	252117	1	Oil Line
22	10430	1	Tube Sleeve
23	10431	1	Nut Fitting (3/8 Tube)
24	*21345	1	Filter Screen (Includes o-rings)
25	11278	1	90° Elbow Fitting

Part numbers marked with an asterisk (*) are contained in Repair Kit No. 090210.

BASIC PUMP ASSEMBLY (BOTTOM VIEW)

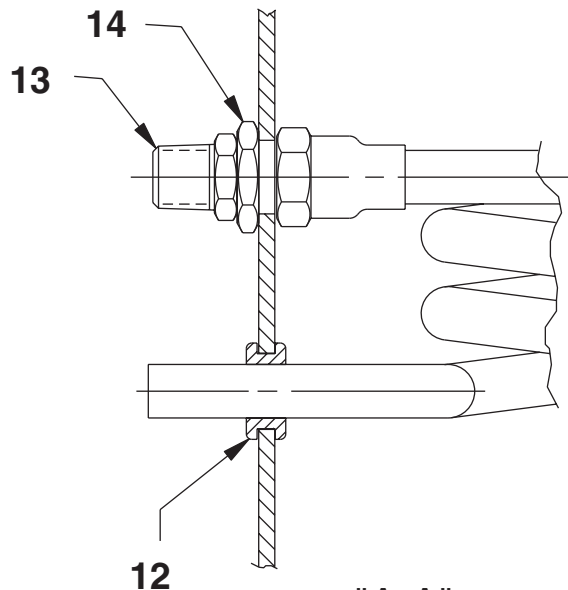
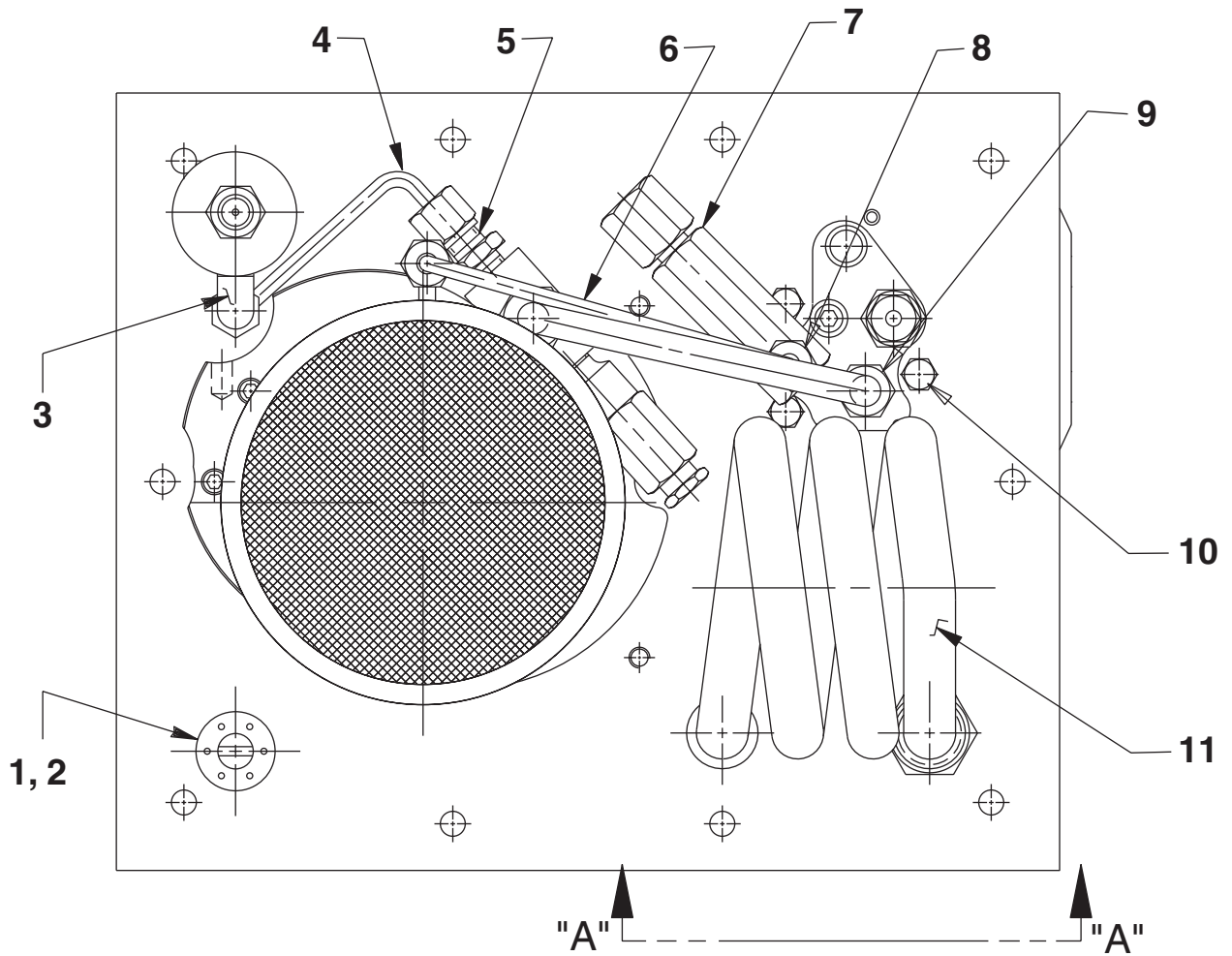

VIEW "A-A"

Item No.	Part No.	No. Req'd	Description
1	20937	1	Vent Cap
2	200415	1	O-ring (13/16 X 5/8 X 3/32)
3	16177	1	90° Elbow Fitting
4	201570	1	Pressure Regulator Tube
5	14844	1	Straight Fitting
6	252118	1	Oil Line
7	21943	1	Accumulator
8	11173	1	Straight Fitting
9	10661	1	Straight Fitting
10	12825	3	Hex Hd. Cap Screw (1/4-20 UNC X 5/8 Lg.)
11	46626	1	Heat Exchanger Coil
12	212896	1	Rubber Grommet
13	251795	1	Straight Fitting
14	251796	1	Hex Jam Nut (1/2 N.P.S.M.)

HYDRAULIC SCHEMATIC

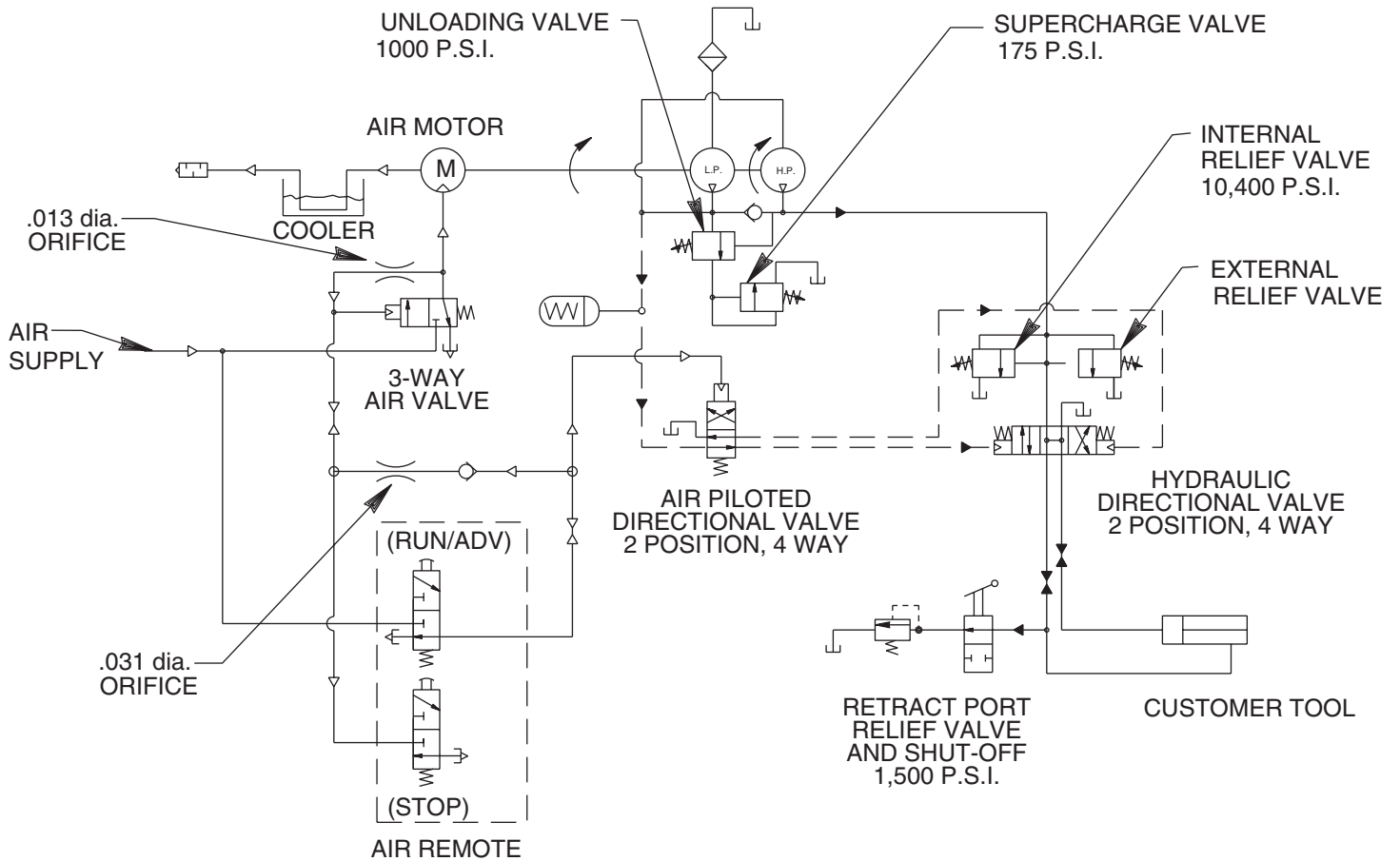

PUMP ASSEMBLY

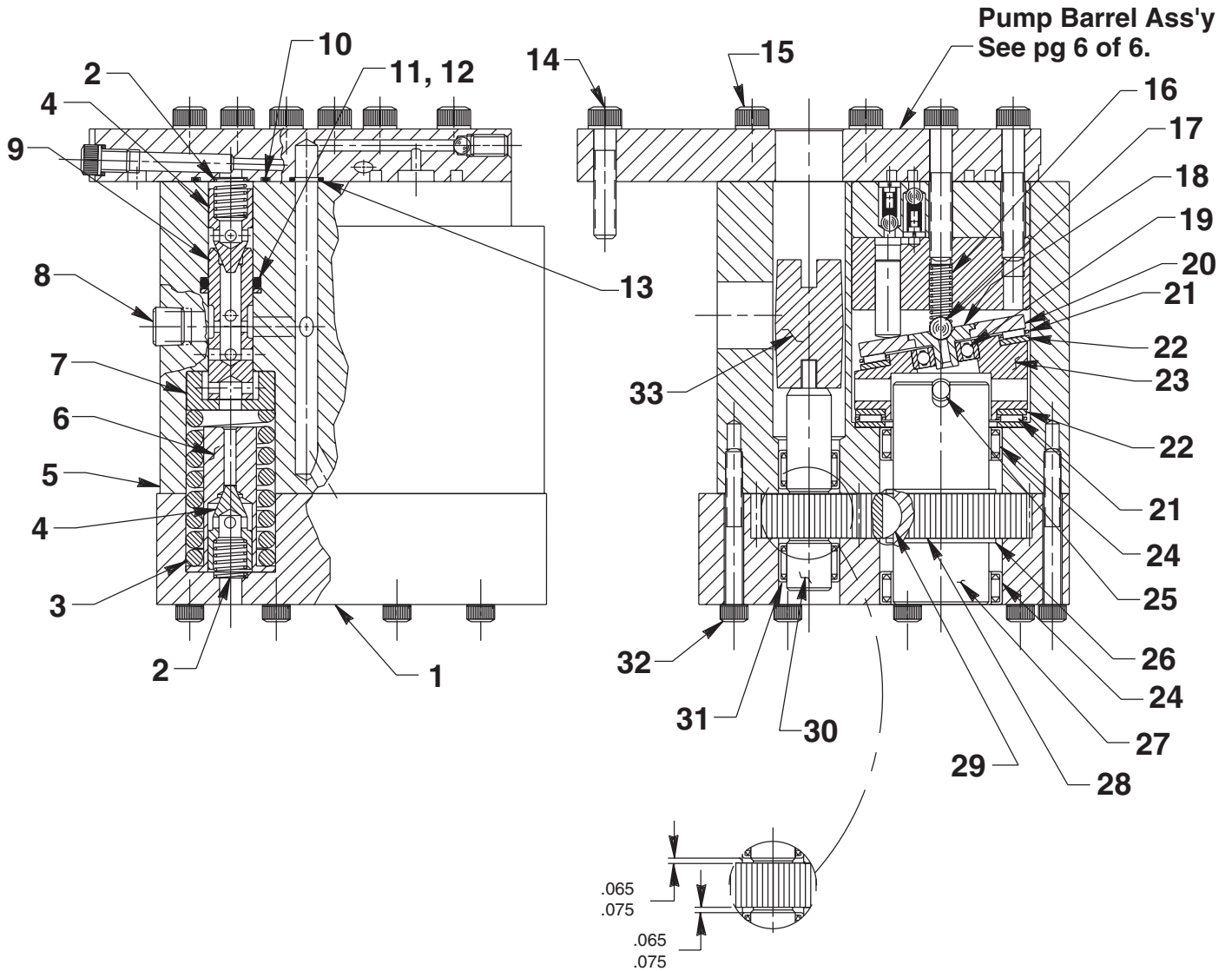

Parts List, Form No.107265, Back sheet 5 of 6

Item No.	Part No.	No. Req'd	Description
1	30533	1	End Plate
2	10425	2	Spring (3/8 O.D. X 3/4 Lg.)
3	10426	1	Spring (1" O.D. X 1-13/16" Lg.)
4	20771	2	Poppet
5	40120	1	Pump Body
6	23256	1	Spring Guide
7	23255	1	Spring Guide
8	10427	1	Plug Fitting
9	20849	1	Spool
10	10303	1	O-ring (7/8 X 3/4 X 1/16)
11	10271	1	O-ring (11/16 X 1/2 X 3/32)
12	12389	1	Backup Washer (11/16 x 1/2 X 1/16)
13	10266	1	O-ring (3/8 X 1/4 X 1/16)
14	10016	1	Hex Soc. Screw (1/4-20 UNC X 1" Lg.)
15	10020	9	Hex Soc. Screw (1/4-20 UNC X 1-1/4" Lg.; Torque to 170/180 in. lbs.)
16	10361	1	Spring (1/4 O.D. X 1" Lg.)
17	10375	1	Steel Ball (1/4" dia.)
18	23547	1	Top Bearing Plate
19	11814	1	Ball Bearing
20	23548	1	Top Plate
21	11228	2	Needle Bearing
22	11813	3	Bearing Race
23	23549	1	Angle Plate
24	11064	2	Needle Bearing
25	11955	1	Slotted Spring Pin
26	11261	2	External Retaining Ring
27	23556	1	Shaft
28	23557	1	Drive Gear
29	11821	1	Woodruff Key
30	21272	1	Drive Gear
31	11199	2	Needle Bearing
32	10001	12	Hex Soc. Screw (#10-32 UNF X 1-3/4" Lg.; Torque to 50/60 in. lbs.)
33	*252108	1	Coupling

Part numbers marked with an asterisk (*) are contained in Repair Kit No. 090210.

#33113 PUMP BARREL ASSEMBLY

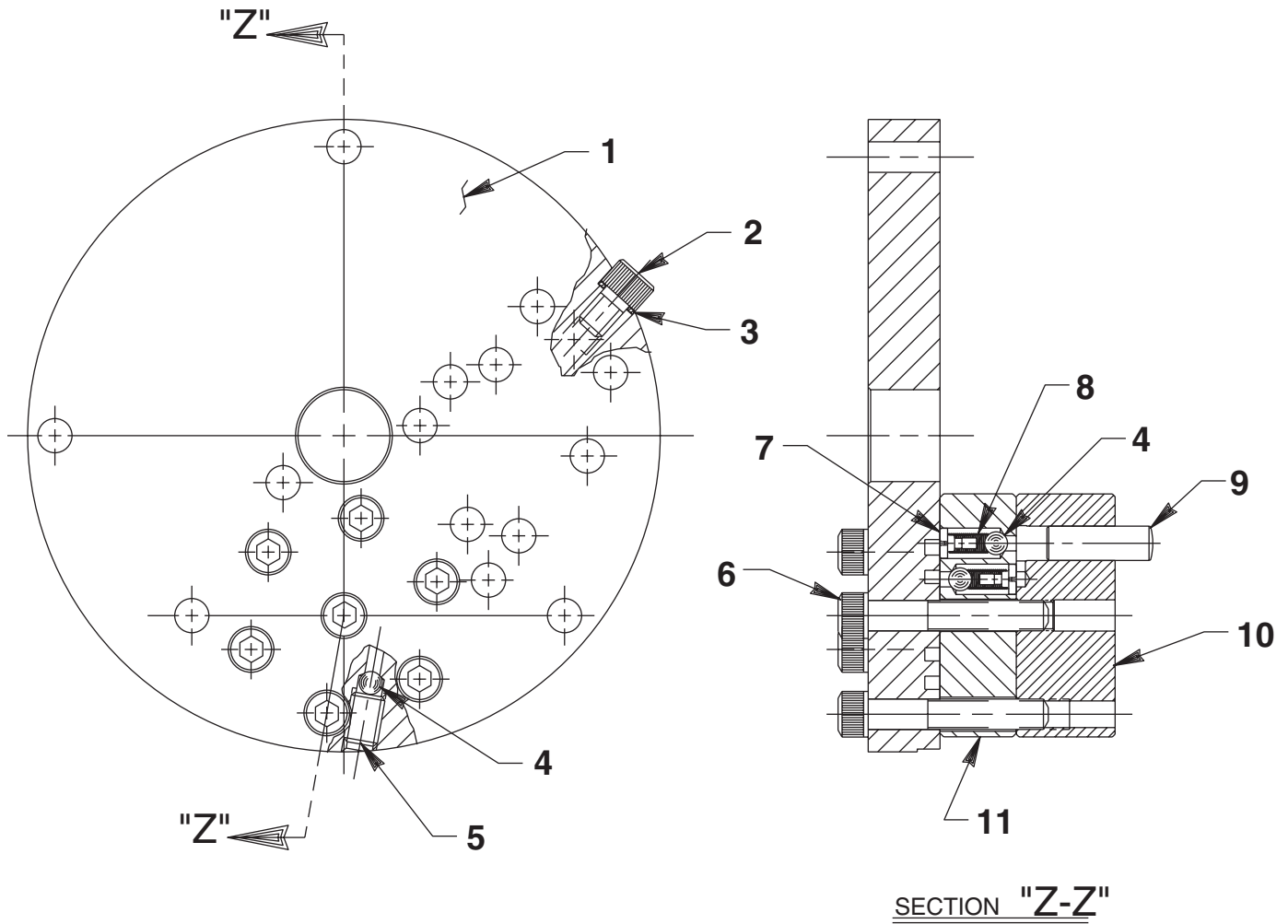

SECTION "Z-Z"

Item No.	Part No.	No. Req'd	Description
1	*50411	1	Top Plate
2	10002	1	Soc. Hd. Cap Screw (1/4-20 UNC X 3/8" Lg.; Torque to 140/160 in. lbs.)
3	10442	1	Special Washer
4	*12223	7	Ball (3/16" Dia.)
5	10519	1	Hex Set Screw (1/4-20 UNC X 3/8 Lg.; Torque to 65/70 in. lbs.)
6	*10023	7	Soc. Hd. Cap Screw (1/4-28 UNF X 1-1/2" Lg.; Torque to 170/180 in. lbs)
7	*24549	6	Ball Guide
8	*10445	6	Spring (5/32 O.D. X 3/4 Lg.)
9	*21628	3	Piston
10	*41062	1	Pump Barrel
11	*40630	1	Valve Head

Consult factory when replacing items marked with an asterisk (*).

HAND SWITCH ASSEMBLY NO. 421257

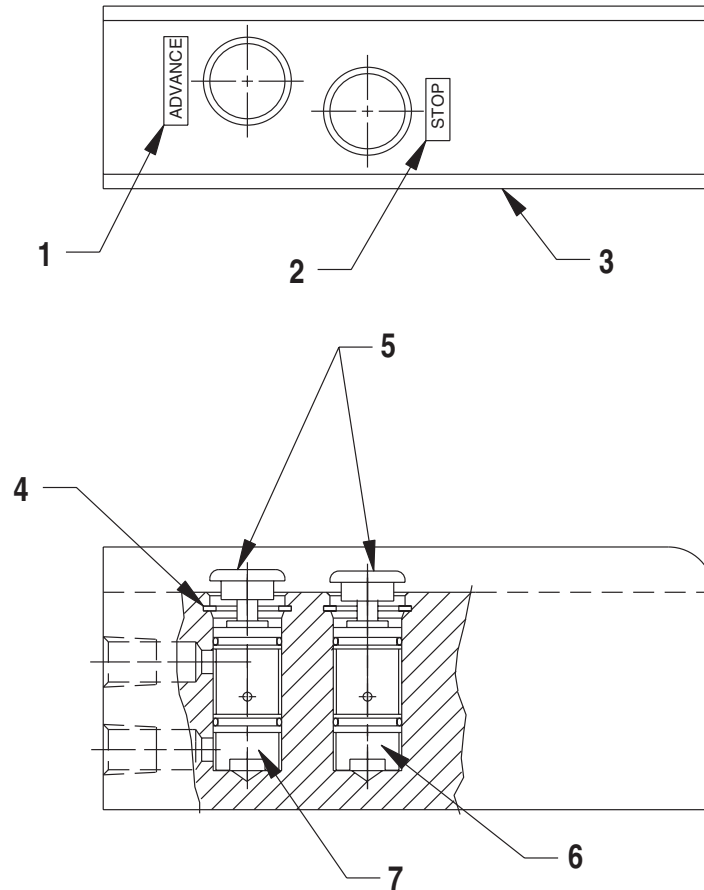

Item No.	Part No.	No. Req'd	Description
1	29663	1	Decal (Advance)
2	203769	1	Decal (Stop)
3	421256	1	Valve Body
4	11033	2	Internal Retaining Ring
5	*206105	2	Push Button
6	*252121	1	3-Way Poppet Valve Cartridge
7	*206104	1	3-Way Closed Valve Cartridge

Part numbers marked with an asterisk (*) are contained in Repair Kit No. 090210.

Note: Complete Hand Switch Assembly No. 421257 is contained in Repair Kit No. 090227-2.